

Ugandan Crop Storage

Submitted to:
Global Livingston Institute
5014, 3001 Brighton Blvd #2662, Denver, CO 80216

ATTN: Tom Karrel

Submitted by:
F19 16.1 ECDS
The Crop Doctors
Engineering, Design, & Society
Colorado School of Mines
Golden, Colorado 80401



Capstone Design@Mines

Final Design Report

Team Members:

Laila Amery (lamery@mines.edu)
Sydney Fesenmeyer (sfesemeyer@mines.edu)
Jessica Horii (jnhorii@mines.edu)
Christopher Linan (cdlinan@mines.edu)
Joson Ralph (josonralph@mines.edu)
Abigail Tiesman (atiesman@mines.edu)

Project Advisors:

Alina Handorean (ahandorean@mines.edu)
Elizabeth Reddy (reddy@mines.edu)

21 April 2020

Acknowledgments

This project has been a very rewarding and eye-opening experience for all members of the group. Travelling internationally to Uganda to personally engage with stakeholders and interact with the community was an essential aspect to design a sustainable solution. With that being said, we would like to thank Global Livingston Institute (GLI) for making this project possible. Thank you to Children of Peace Uganda (CPU) for working with us to make your vision a design, and providing us with much of the information needed in this project. We would like to extend our deepest appreciation to both GLI and CPU for hosting us in Uganda and allowing us an unforgettable experience.

Thank you to Dr. Elizabeth Reddy and Dr. Alina Handorean for advising us through this process and providing valuable feedback and considerations. You both have expanded our thinking and worldviews in designing for international communities.

Thank you to Dr. Reza Hedayat, Dr. Joseph Crocker, Samuel Engola Okello, and Dr. Paulo Tabares for providing technical expertise. We appreciate the time you have taken to assist in our project.

Last but not least, we would like to thank the friends and family for seeing the value in our project and helping make our trip to Uganda possible. We would also like to express our gratitude to the on-campus departments of Humanitarian Engineering, Humanities Arts & Social Science, and the International Office for their generous contributions along with the Hope's Enduring Flame Foundation.

Table of Contents

Executive Summary	3
1. Introduction	4
2. Project Review	4
3. Application of Design Methodology	6
4. Engineering Analysis	7
Table 1: Calculation for space needed in facility	7
Table 2: Useable storage volume calculation	8
5. Final Deliverables	9
6. Project Management	10
7. Lessons Learned	10
Appendix A: Technical Drawings of the Facility	12
Figure 1. Floor plan of proposed facility	12
Figure 2a. SolidWorks model of the proposed facility	12
Figure 2b. Rotated view of SolidWorks Model	13
Figure 3a: Solidworks model of facility with roof	13
Figure 3b: The roof overhangs to block direct sunlight from entering the storage area windows	14
Figure 4: Dimensioned drawing of storage facility layout	15
Figure 5: Wireframe Model	16
Figure 6: Doors in sequence from loading area to storage room	16
Appendix B: Pictures from Uganda	17
Figure 7: The land owned by CPU where the storage facility will be built	17
Figure 8a: The Barber farmer group in Lira who partners with CPU and will benefit from the storage facility	17
Figure 8b: The Barlonyo farmer group in Lira who partners with CPU and will benefit from the storage facility	18
Figure 9: An empty grain storage bag used by the farmers to both transport and store their crops	18

Ugandan Crop Storage

Prepared by: Laila Amery, Sydney Fesenmeyer, Jessica Horii, Christopher Linan,
Joson Ralph, Abigail Tiesman

F19 16.1

The Crop Doctors

College of Engineering and Computational Sciences
Colorado School of Mines

Executive Summary

Agriculture employs nearly seventy percent of the workforce in Uganda, but many farmers lose up to forty percent of their harvest due to improper food storage practices. Uganda has a very tropical climate and crops oftentimes are lost to exposure at high humidity and temperature levels, since the harvest is currently stored in the residences of the farmers, which are small mud huts with grass roofs. Given the current storage situation, fire, mold and pest infestation, and theft appear to be the most significant concerns.

Our task is to design a stakeholder approved communal crop storage facility. The ability to store the crops would allow the farmers the opportunity to sell their harvest at a low supply time in the market, yielding much higher profit margins. This new cycle of storing and increasing profit stimulates the local economy and allows for new community opportunities, such as children receiving formal education.

Our client is Global Livingston Institute, a non-profit organization based in Denver that focuses on East African development projects. Their motto is “Listen, Think, Act” and thus take community research and stakeholder engagement into consideration before moving forward. Given the country’s instability and trauma in previous years, Global Livingston has partnered with other local organizations to rebuild rural communities. These organizations both work together to ensure successful and sustainable models for development, and discovered the need for the crop storage facility.

The engineering challenge is to design a communal crop storage facility able to store two different grains with their respective optimal temperature and humidity levels, with limited access to modern technology and resources.

1. Introduction

The client the team worked for throughout the year is Global Livingston Institute (GLI). Global Livingston Institute is a non-profit organization that is focused on innovative approaches to international development. It was founded in 2009 with the motto of Listen, Think, Act. Global Livingston partners with multiple universities around the United States, and approached the Colorado School of Mines with this Senior Design proposal: work with the people of Uganda to create a crop storage facility that best fits their needs.

The team also worked alongside Children of Peace-Uganda (CPU), who presented the initial idea of designing a crop storage facility for the community. CPU is another non-profit organization whose main goal is to reintegrate former child soldiers into society. Between 1988 and 2004, the Lord's Resistance Army (LRA) led by Joseph Kony in Uganda abducted approximately 30,000 children. These children were forced to participate in Kony's work, committing extremely violent crimes causing lasting trauma. After a peace agreement was finalized in 2008, many former child soldiers were left without families or a means to make a living. CPU is currently working to educate these former child soldiers on agricultural practices so they are able to support themselves.

Agriculture is a major pillar of the Ugandan economy and it employs nearly seventy percent of the labor force. The problem at hand is that about forty percent of the harvest each year is lost due to poor storage conditions and environmental factors. Currently, farmers use their homes to store their livelihood, but they face the immense obstacles in trying to preserve their crops post-harvest. Because of the significant loss in crops and limited storage options and available transportation, farmers are often forced to sell their crops at a low rate when the market is saturated at harvest time. This causes a cycle of poverty, never allowing the farming community the opportunity of financial growth and economic development.

Our project not only aims to create a storage facility to better farmers' livelihoods, but to also create a lasting legacy allowing for child soldiers to reintegrate into society and continue their healing process through successful agriculture.

2. Project Review

The problem we are tasked with solving is crop losses due to inadequate storage methods for crops harvested in Uganda. Most people depend on agriculture to support their families. When the harvested crops are not dry enough and exposed to the environment, it is easy for insects to infect and destroy the crops, or for mold to grow. The crops cannot then be sold and revenue is lost. To better protect the crops after harvest, we are planning to build a communal storage facility for farmers to store their crops for months after harvest. The most efficient way to protect crops is to store them in an airtight environment. This will keep moisture and insects away from the crops. The crops will be weighed and recorded in an on-site office, so each farmer

will earn their fair wage. This will be done in the front room of the facility that can be open to the outside environment and doors can be left open for loading or unloading. There will be a facility employee to aid in the weighing process, recording, and provide security. When this employee is not present, the facility will be locked and inaccessible.

The first steps of this project was to research how to store crops in Uganda and then brainstorm potential concepts for the various components of the facility. This included facility layout, storage methods, energy options, windows, doors, and structure materials. We used the first three months of the project to thoroughly explore various options and decide on what would be the best concepts moving forward.

At this stage in the design process, we had selected a three room concept that can be seen in the final layout in Figure 1 of Appendix A and considered a wooden storage bin to aerate the crops may be a feasible storage method. Given the initial requirement to store 200,000 kg of each crop, we were able to calculate the volume required for each bin. However, after our trip to Uganda, we learned that storage in bags is a better option and aeration of the crops while in storage is not needed.

We determined that solar power would be the most achievable option to provide energy to the facility. There are several solar energy options from the brand Sun King which can be found through the retailers Greenlight Planet and M-Kopa Solar, who both provide service to Uganda. These companies offer products that will provide power for our design which will make the operations easier and the ability for the storage facility to be used during low-light conditions.

When considering windows and doors, we researched affordable and accessible options to meet our design criteria, and decided on garage doors for the loading dock. We had planned a window design with long narrow windows near the top of the wall in the storage space so the overhang from the roof could protect the crops from direct sunlight. The front room is able to contain large windows to let in a lot of light to reduce electricity needs..

We initially thought both the walls and roof of the facility could be made of PBR panelling, but after consulting CPU's engineer Samuel, we learned that these metal panels for walls may not be strong enough to withstand forces from flooding. A better design would be to make the walls out of locally manufactured clay bricks.

A major turning point in our project was the opportunity to travel to Kampala and Lira, Uganda in February; about 5 months into the work on the project. We were able to gain a clearer understanding of the context of the desired storage facility. We saw the need for a facility firsthand, and the organizations involved in making it possible. We learned about Ugandan culture and spoke to the farmers, who are the direct stakeholders in the project. This trip was an important element in connecting with Children of Peace Uganda (CPU) and understanding their visions for the project. The conversations we had with Global Livingston (GLI), the farmers, and CPU revealed the discrepancies in desired project outcome. CPU was planning for a single, large facility located in urban Lira on CPU owned land, while the farmers struggled with the idea of sending their livelihood so far away. The farming communities suggested creating smaller

facilities that are more widespread on farmer owned land. We found this to be unexpected and challenging to consider. CPU was sure that they could gain the farmers' trust so the farmers would be willing to store their crops away from their homes. As a result, we decided that a single large facility made geographical and economical sense.

3. Application of Design Methodology

This project's objective is to design a facility for both sorghum and soybeans, the major crops that are produced by farmers in the city of Lira, in Northern Uganda. This facility should be easily accessible, secure, user friendly, and resistant to pests and moisture. Based on information from the local community, we are to design the facility with very low or no electricity options as well as low water usage. One of the main challenges in this design is the limited access to reliable technology with the developing state of the country. An initial idea was to create a simple in ground storage cellar, but this would not allow for the proper storing conditions of each grain. After individual grain condition research, we discovered we needed to design a warehouse like building with simple methods for adjusting temperature and humidity as needed.

Given the limited resources available, we conducted research to determine the most efficient solar powered system to include in our design implementation. These solar panel manufacturers are located throughout Uganda, allowing for easier purchasing and maintenance options. Adding low levels of power to the facility will significantly increase the facility's usability and capability.

Additional concepts were selected for garage doors and facility windows, as well as loading bay areas. These factors encompass the total functionality of the storage and receiving area, from physical structure to internal offices and break areas.

We were allowed the incredible opportunity to travel to Uganda to conduct field research and engage with stakeholders directly. Visiting the country was a critical component in our design approach because one of the most important aspects of community design projects, particularly in third world countries, is receiving direct stakeholder input. Community outreach is extremely important to ensure a successful and sustainable project, as this facility needs to meet their needs and match their lifestyle.

This trip was a valuable opportunity to get a full understanding of who will be using our facility and the immense need for improved storage options. After much communication with our client and stakeholders, we were able to explore their differing perspectives. The main difference is that Children of Peace, who is leading the project, was planning for a single large storage facility on land that they own in town, while the farmers, who will be using the facility to store their crops, did not trust having their crops so far away from them and wanted many smaller storage facilities in their communities a couple miles outside of town. The farmers cannot build the storage facility on their own, but if CPU builds it on their land in town and the farmers don't

use it, then it was a pointless project. We used the knowledge we gathered during the trip to make a recommendation for a single storage facility, but only if CPU can gain the trust of the farmers. The main takeaway from our experience was the various local community issues that factor into the project.

We used Solidworks renderings and drawings to convey the concept of our facility. We also used simple Revit modelling to show the design in a different way. These tools were essential for us to show exactly what we were thinking and to give a complete picture of the facility.

4. Engineering Analysis

The majority of the engineering decisions made were based on observations made while traveling to Uganda. Valuable information such as logistics on materials and how the layout of the facility should be were obtained from the employees of CPU.

We determined that storage rooms that are almost 15 meters wide and 35 meters long would be sufficient to store 200,000 kilograms of crop, with some extra space for surplus or other crops to be stored as well. These dimensions used the area of the land efficiently while allowing proper storage space. Each grain storage bag weighs roughly 100 kilograms and so each room must be capable of storing 200 bags. Using the density of each crop, we determined that about 265 m³ of space was needed for soybeans and 246 m³ of space was needed for sorghum (see Table 1). The walls of the facility are 6m high and it is estimated that 3m of that height can be used for storage bags. Giving space for walking in the door and some walking space on the floor, the volume of crop each room can hold is 1080 m³ (see Table 2). This is more than 4 times the amount of space required and allows for space to bring bags in and out, space to store additional crop surplus, space to store other kinds of crops and to account for the bags not fitting perfectly together. If more of the 6m vertical space can be used by strategically stacking the storage bags, then the usable volume could potentially triple or more. Even with all the extra storage space, we believe that this design is compact and is good use of the land.

Table 1: Calculation for space needed in facility

Crop Type	Density (kg/m ³)	Storage Needed (kg)	V needed (m ³)	V simplified (m ³)
Soybeans	753	200,000	265.6042497	265
Sorghum	811.54	200,000	246.4450304	246

Table 2: Useable storage volume calculation

	Dimensions	Reasonably Useable Dimensions
Wall Height	6m	~3m
Storage Room Length	35m	30m
Storage Room Width	14.95m	12m
Total Volume		~1080 m ³

During the course of the project, we did not have access to the materials that are available to the client in Uganda to build the facility in order to test their strength. However, based on discussions with CPU and observations of other buildings during our trip to Uganda, we believe that clay bricks for the walls would be strong enough to withstand potential forces from wind and rain. In the future, it would be beneficial for a team in Uganda to obtain the locally made clay bricks to be used and test how much horizontal force a wall can withstand. Similarly with the metal roof, many buildings in Uganda use this material and so it is not likely there will be issues with the strength.

There were a couple of things we did not get to analyze as deeply as would be required to quickly start construction with our plans alone, one being the design of the trusses required to support the roof. Our facility is quite a bit bigger than other buildings we saw while in Uganda so the roof supports need to be analyzed before building to avoid structural failure. Information on the strength of the trusses as well as the joints and connections between trusses would aid in these calculations. Going along with this, the foundation would need to be analyzed deeper with information we didn't have access to such as the characteristics of the soil being built on as well as the strength and type of the concrete used.

Analysis is still needed on temperature and humidity monitoring devices and controls. We have done extensive research on the needed equilibrium moisture content that the crops last best with, but analysis is still needed on controlling the humidity and temperature in a building. There still needs a bit of work looking into how different methods of cooling, like an air conditioning unit, will control the air in the entire building. This might also not be necessary, so further analysis should be performed on the quality of the crops stored at a building without cooling. The climate is fairly moderate in Uganda in terms of crop storage conditions, and electricity is limited. This analysis is needed to determine if the additional cooling is necessary.

Given that our design includes locally sourced materials and they have not been completely specified, we are unable to provide a budget at this time. Through further contact with the Children for Peace Uganda team and technical experts, our facility design plans will

become more accurate, therefore hopefully allowing a more detailed budget outlining expenses. Ideally, this budget will include not only construction and facility costs, but also estimated expenses for the facility in terms of employee compensation and maintenance.

5. Final Deliverables

Images of the final storage facility can be seen in Appendix A and each highlights a different portion of the design.. Figure 1 shows the layout of each room with labels. Additionally, Figure 3a shows a complete 3D model of the facility. A dimensioned drawing of the facility is shown in Figure 4, and can be used for a more in depth understanding of the previous renderings. Figures 5 and 6 give a different perspective on the layout of the facility and helps with getting a complete view of the design. Finally, Appendix B contains pictures from our travels to Uganda that were important in getting a clear idea of how technical ideas will be translated to real world crop storage facility.

There are many different parts of the facility and each has its role in making the design successful. The loading dock will be located in the front right portion of the facility as seen in Figure 2a (Appendix A). Figure 2b is simply an alternate view of the facility to clearly see all aspects. It will be standardized to accommodate large vehicles such as trucks. We recommend the use of an adjustable loading ramp to assist with the unloading of crops from different sized vehicles. Upon entering the facility, an office space will be located to the left of the entrance with an adjacent kitchen and washroom. The washroom will be able to be accessed by all guests while the kitchen will only be accessible through the office which will ensure employees sole use. This portion of the facility will have large windows in order to maximize natural lighting that can also open to provide airflow. The height of the walls surrounding the office, kitchen, and washroom will be about 3 meters tall, making them shorter than the height of the storage rooms. An exterior door along the right side of the building will lead to an area for crops to be dried.

Moving further into the facility, two sets of double doors are located on the back wall of the front room. These two sets of doors will lead to two separate storage rooms. To keep the storage rooms close to hermetic and cool, there will be no direct sunlight entering the storage spaces with the roof overhang over the windows (see Figure 3b). Additionally, the implementation of two doors in succession between the front and storage rooms act as a buffer to limit the exterior environment from entering the storage areas. The ceiling height of the storage areas will be roughly 6 meters tall to optimize vertical storage capacity. Windows will be built into the storage rooms for natural lighting, however an overhang of the roof will assist with keeping out direct sunlight. The windows will be aluminum-framed since they won't need to open, and come from a local store in Uganda. USB powered temperature and humidity devices can be used to test the conditions of storage. The entire structure will sit on a concrete foundation that will help keep the facility airtight and pest free. The building itself will be mostly made out of clay bricks, which are locally found in Lira, Uganda and more affordable than the concrete option. The roof will be the same height around all of the interior to maximize the simplicity of

the design. The roof will be double-pitched with metal panels to minimize the accumulation of water during periods of heavy rainfall. During periods of precipitation, the rainfall will be guided through a gutter system which will eventually lead the stormwater to a retention pond. This pond water can then be recycled throughout the water system of the facility.

External to the facility, solar panels and a water tank will be stationed next to the building. These solar panels would have the ability of providing electricity to the facility for various purposes. The solar panels are planned to be roughly 2 m off the ground and have the ability to rotate for optimal sunlight intake. The external water storage tank will collect rainwater adjacent to the facility and will provide for the kitchen, washroom and storage rooms. Runoff will also be captured in the structure's gutter system which will then transport it to a retention pond. This has the potential to be used for the facility or drained into a nearby creek.

Security of the facility was a major concern expressed in the design process. The structure will be surrounded by a brick wall which will have razor wire on the top. In addition, there will be a guard post located at the entrance of the facility to regulate traffic coming in and out. There will also be security lights outside the facility that will be on throughout the course of the night.

6. Project Management

At the current stage of the design process, we do not have a finalized budget. Due to recent events with the pandemic, our goals for the project have shifted to cataloging all of the information we have accumulated over the past six months. If the project were to get passed on to another group next year, we hope that the next group will be able to use the research we have collected to finalize the design and work with GLI and CPU to actually implement the project. The main concept for the design is pretty established, but there are many details that can still be improved. Some aspects that still need improvement are the systems used for cooling and humidity control, and choosing final products for solar panels and a water detention pond. We recommend that the new group travel to Lira, Uganda, and continue building relationships with the farmer groups and learning about the situation in the country. This team next year should continue researching this concept, as well as exploring other options like smaller facilities closer to farmer groups. We feel that we have completed a ton of research, but there are still different interests between the clients and the stakeholders, so we suggest a future group continues evaluating options. There are many obstacles, such as security and transportation, that should be further considered.

7. Lessons Learned

Throughout this project, we were exposed to many situations and challenges we had never faced before. One lesson we learned was the importance and impact of considering local community thoughts and desires when designing an engineering project. It is more than just

technical work. This came from experience as well as from working with GLI and some of the work we did in the ECDS capstone studio. GLI's motto is "Listen, Think, Act", and throughout the process they emphasized listening to the actual stakeholders instead of just jumping straight into engineering. We also learned in class about the Bridger and Luloff Criteria and how to design for other communities. When we actually visited Uganda and talked to the farmers, this lesson became really prominent. We realized some components we were considering were not even available in Uganda, and the farmers had very different priorities in the design. If we were to move forward with the design we had before visiting, the facility would most likely fail because it was not what the stakeholders wanted. Understanding that different cultures have different expectations and "norms" is important to gain their trust and receive their opinions on the project.

This was also a new experience for us, working with so many different stakeholders, especially so spread out around the world. Communication between all the groups involved in a project is key because differing opinions can halt progression if compromise is not reached. Each group we worked with has a different perspective on the project. The farmers would be using the facility, CPU will be managing the facility, and GLI will be a big help in funding the facility. All groups are vital to the success of the project, but everyone has their own experiences and ideas that need to be considered. An important part of working with these groups is flexibility and patience when communicating, especially in different time zones and with some people who do not all speak the same language.

We also learned many lessons to do with project management and approaching a design problem. We learned asking for help from experts in their field is important to the success of a project. It is impossible to know everything ourselves, but there are so many people with a lot of experience willing to help. One of the most beneficial days in Uganda for our team was reviewing the design with Samuel, an engineer in Lira, who shared a lot of information about building norms in Uganda. We also learned about helpful practices for projects of this scale. Organization of project material is important when it is long and extensive so that information can be found quickly. We were compiling a lot of different information, and we got better at collaborating on assignments and reports.

Thank you!

Appendix A: Technical Drawings of the Facility

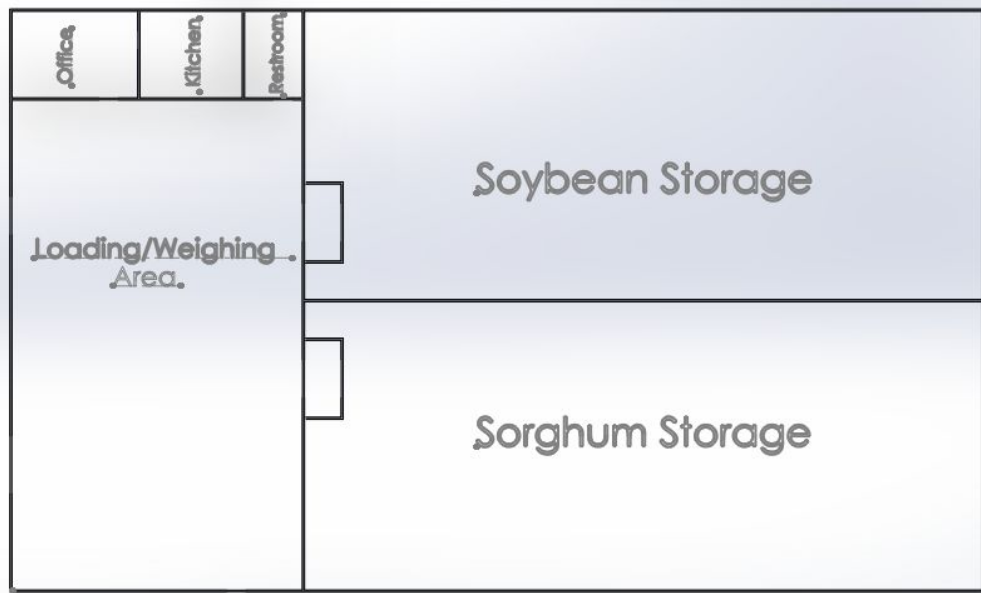

Figure 1. Floor plan of proposed facility

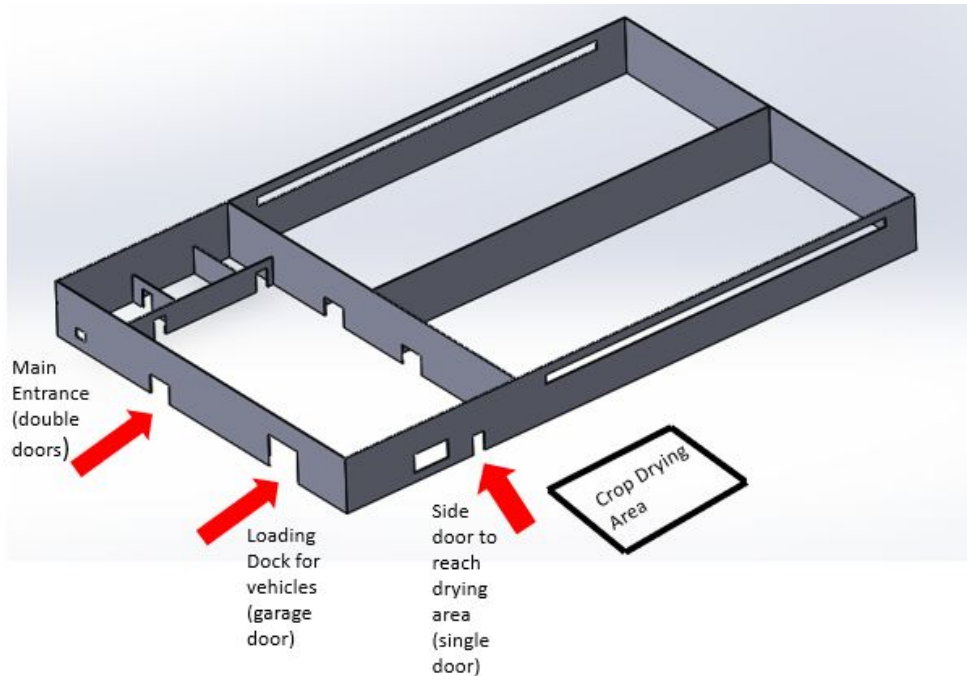

Figure 2a. SolidWorks model of the proposed facility

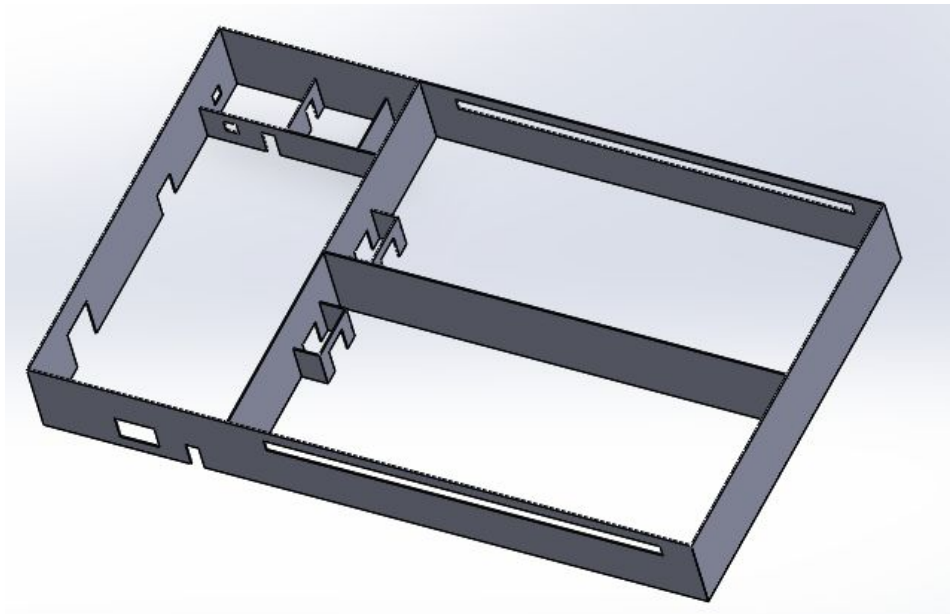

Figure 2b. Rotated view of SolidWorks Model

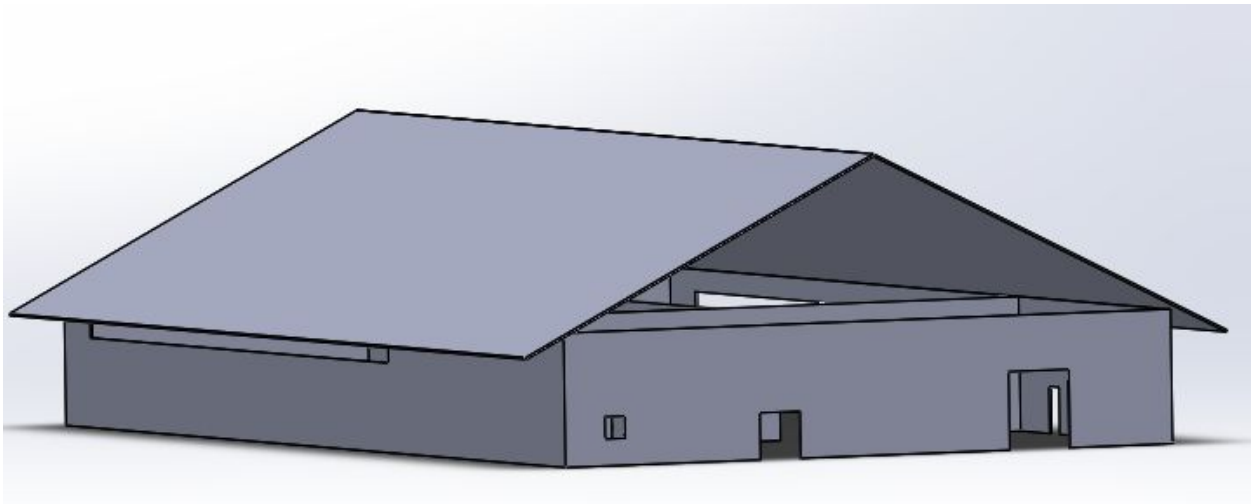

Figure 3a: Solidworks model of facility with roof

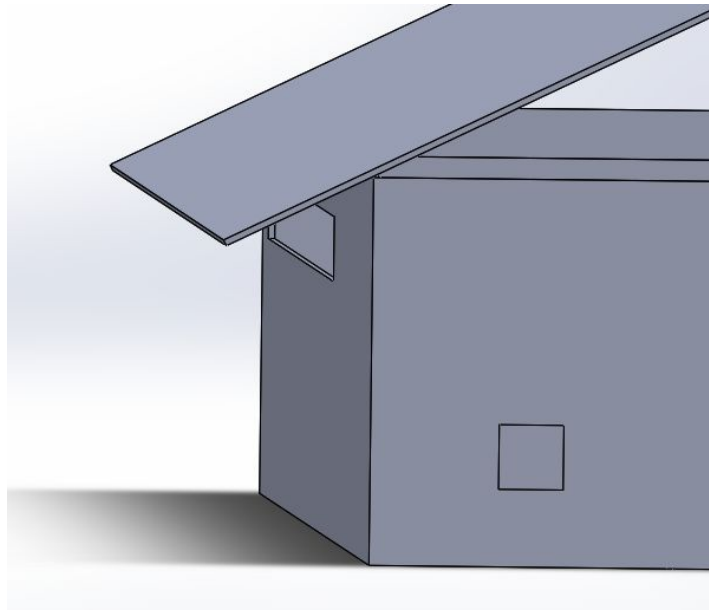

Figure 3b: The roof overhangs to block direct sunlight from entering the storage area windows

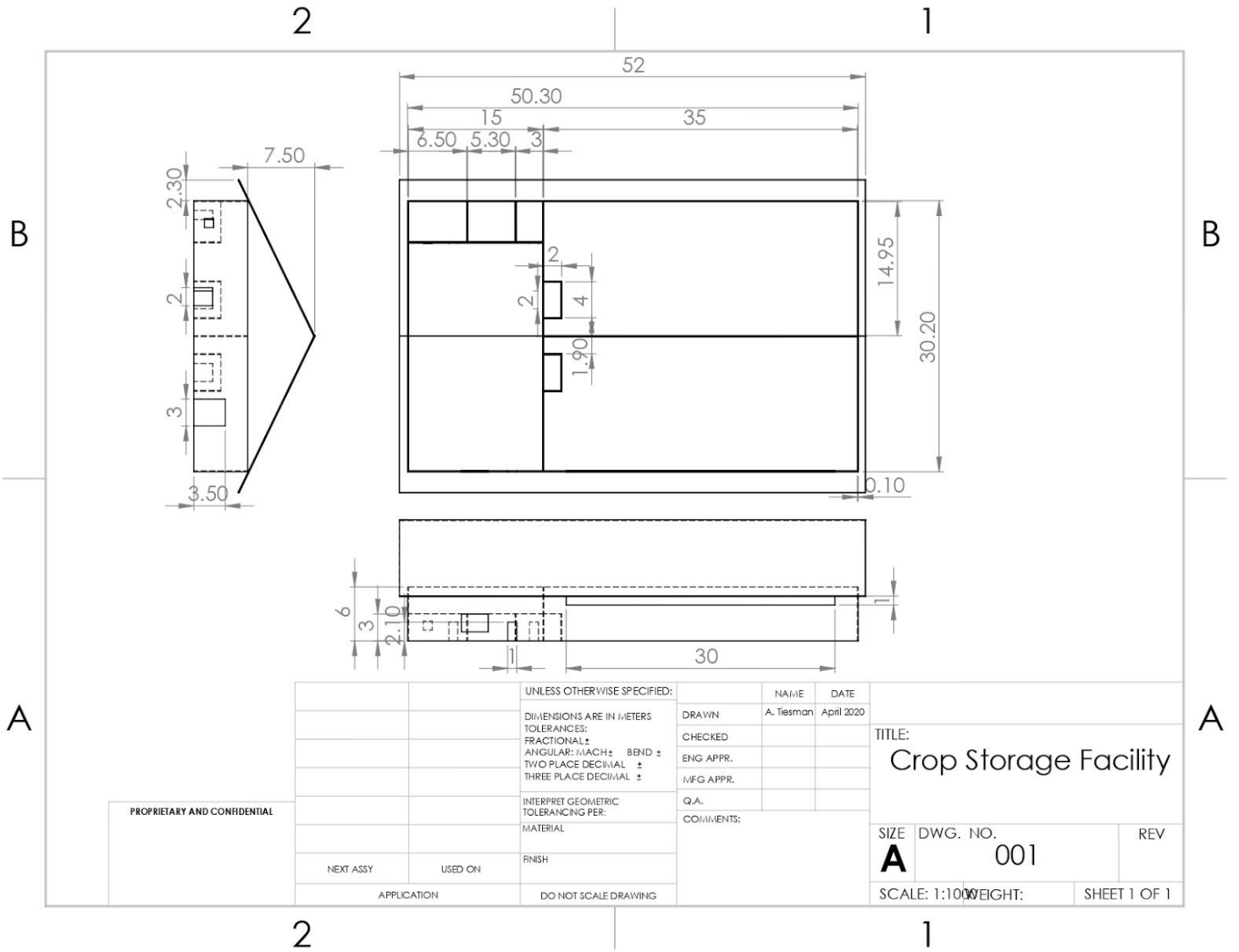

Figure 4: Dimensioned drawing of storage facility layout

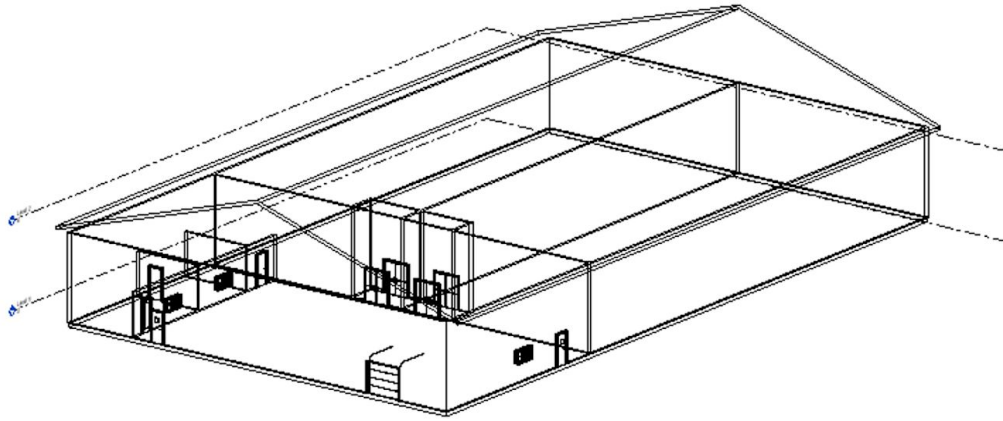

Figure 5: Wireframe Model

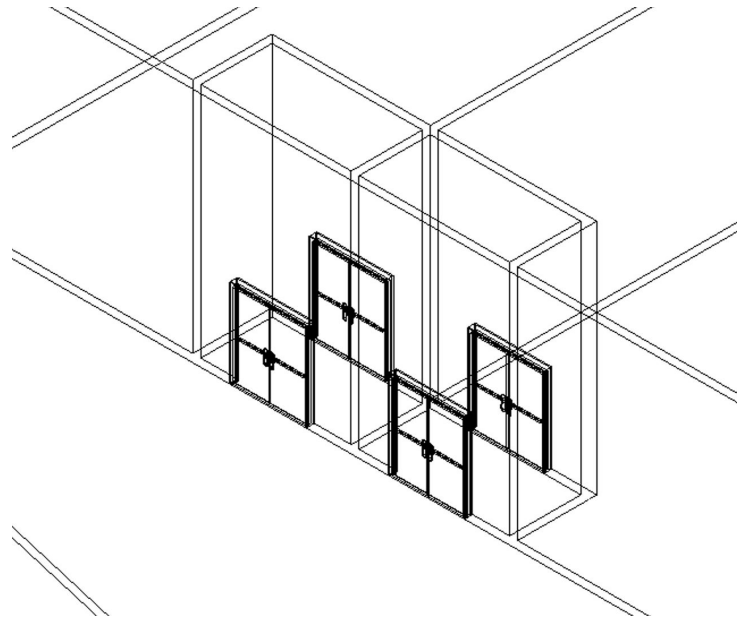

Figure 6: Doors in sequence from loading area to storage room

Appendix B: Pictures from Uganda



Figure 7: The land owned by CPU where the storage facility will be built



Figure 8a: The Barber farmer group in Lira who partners with CPU and will benefit from the storage facility



Figure 8b: The Barlonyo farmer group in Lira who partners with CPU and will benefit from the storage facility



Figure 9: An empty grain storage bag used by the farmers to both transport and store their crops